

DDR5-1.10V

Unbuffered DIMM Module

**8 GB based on 16Gbit
component**

FBGA with Pb-Free



Revision 1.0 (Dec, 2023)

1.0 Feature

- DRAM VDD/VDDQ = 1.1V (-33mV / +67mV)
- DRAM VPP = 1.8V (-54mV / +108mV)
- 16 Bank with x16
- 8 BG(Bank Group)
- BL16, BC8 OTF, BL32, BL32 OTF supported
- Temperature Encoding
- Same Bank Refresh
- VrefDQ / VrefCA / VrefCS Training
- Hard/Soft Post Package Repair
- Input Clock Frequency Change
- Maximum Power Saving Mode (MPSM)
- Multi-Purpose Command (MPC)
- Per DRAM Addressability (PDA)
- Read Training Mode
- CA Training Mode
- CS Training Mode
- Per Pin VREFDQ Training
- Write Leveling Training Mode
- Connectivity Test (CT)
- ZQ Calibration
- DFE (Decision Feedback Equalization) for DQ
- DQS Interval Oscillator
- 1N / 2N Mode support for Commands
- On-Die ECC
- ECC Transparency and Error Scrub
- CRC (Cyclic Redundancy Check)
- Loopback for multiple purposes - monitor data, BER(Bit Error Rate) analysis, etc.
- Package Output Driver Test Mode
- This product is in Compliance with the RoHS directive
- DIMM Dimension (Nominal) 31.25 mm high, 133.35 mm wide
- Based on JEDEC standard
- RoHS compliant & Halogen Free
- Gold plated contacts

2.0 Ordering Information

Part number	Density	Module Organization	Component composition	Component PKG	Module Rank	Description
ZHMCG66AGBU081Y1	8GB	1Gx64	1Gx16 (H5CG46AGBDX017N)*4	FBGA	1	8GB 1Rx16 PC5-5600U

3.0 Key Timing Parameters

	DDR5-5600	Unit
CL-tRCD-tRP	46-45-45	tCK
CAS Latency	16	tCK
tCK	0.357	ns
tRCD	16.00	ns
tRP	16.00	ns
tRAS	32.00	ns
tRC	48.00	ns

4.0 Absolute Maximum DC Rating

Symbol	Parameter	Rating	Units
VDD	Voltage on VDD pin relative to Vss	-0.3 ~ 1.5	V
VDDQ	Voltage on VDDQ pin relative to Vss	-0.3 ~ 1.5	V
VPP	Voltage on VPP pin relative to Vss	-0.3 ~ 2.1	V
VIN, VOUT	Voltage on any pin relative to Vss	-0.3 ~ 1.5	V
TSTG	Storage Temperature	-55 ~ + 100	°C

5.0 Address Configuration

Organization	Bank Group Address	Row Address	Column Address	Bank Address	Page Size
1Gx64 (16 Gb) base	BG0~BG1	R0-R15	C0-C9	BA0-BA1	2 KB

6.0 DIMM Pin Configurations (Front side/Back side)

Pin	Front	Pin	Front	Pin	Front	Pin	Back	Pin	Back	Pin	Back
1	VIN_BULK	49	DQ29_A	97	CB0_B	145	VIN_BULK	193	VSS	241	VSS
2	RFU	50	VSS	98	VSS	146	VIN_BULK	194	DQ31_A	242	CB2_B
3	RFU	51	CB0_A	99	CB1_B	147	PWR_GOOD	195	VSS	243	VSS
4	HSCL	52	VSS	100	VSS	148	HSA	196	CB2_A	244	CB3_B
5	HSDA	53	CB1_A	101	DQ0_B	149	RFU	197	VSS	245	VSS
6	VSS	54	VSS	102	VSS	150	VSS	198	CB3_A	246	DQ2_B
7	RFU	55	DQS4_A_c	103	DQ1_B	151	PWR_EN	199	VSS	247	VSS
8	VSS	56	DQS4_A_t	104	VSS	152	RFU	200	ALERT_n	248	DQ3_B
9	DQ0_A	57	VSS	105	DQS0_B_c	153	VSS	201	VSS	249	VSS
10	VSS	58	CS0_A_n	106	DQS0_B_t	154	DQ2_A	202	CS1_A_n	250	DM0_B_n
11	DQ1_A	59	VSS	107	VSS	155	VSS	203	VSS	251	VSS
12	VSS	60	CA0_A	108	DQ4_B	156	DQ3_A	204	CA1_A	252	DQ6_B

288-Pin Unbuffered DIMM
DDR5 SDRAM

13	DQS0_A_c	61	CA2_A	109	VSS	157	VSS	205	CA3_A	253	VSS
14	DQS0_A_t	62	VSS	110	DQ5_B	158	DM0_A_n	206	VSS	254	DQ7_B
Pin	Front	Pin	Front	Pin	Front	Pin	Back	Pin	Back	Pin	Back
15	VSS	63	CA4_A	111	VSS	159	VSS	207	CA5_A	255	VSS
16	DQ4_A	64	CA6_A	112	DQ8_B	160	DQ6_A	208	CA7_A	256	DQ10_B
17	VSS	65	VSS	113	VSS	161	VSS	209	VSS	257	VSS
18	DQ5_A	66	CA8_A	114	DQ9_B	162	DQ7_A	210	CA9_A	258	DQ11_B
19	VSS	67	CA10_A	115	VSS	163	VSS	211	CA11_A	259	VSS
20	DQ8_A	68	VSS	116	DM1_B_n	164	DQ10_A	212	VSS	260	DQS1_B_c
21	VSS	69	CA12_A	117	VSS	165	VSS	213	RFU	261	DQS1_B_t
22	DQ9_A	70	RFU	118	DQ12_B	166	DQ11_A	214	RFU	262	VSS
23	VSS	71	VSS	119	VSS	167	VSS	215	VSS	263	DQ14_B
24	DM1_A_n	72	CK0_A_t	120	DQ13_B	168	DQS1_A_c	216	CK1_A_t	264	VSS
25	VSS	73	CK0_A_c	121	VSS	169	DQS1_A_t	217	CK1_A_c	265	DQ15_B
26	DQ12_A	74	VSS	122	DQ16_B	170	VSS	218	VSS	266	VSS
27	VSS	75	RFU	123	VSS	171	DQ14_A	219	RFU	267	DQ18_B
28	DQ13_A	76	RFU	124	DQ17_B	172	VSS	220	RFU	268	VSS
29	VSS	77	VSS	125	VSS	173	DQ15_A	221	VSS	269	DQ19_B
30	DQ16_A	78	CK0_B_t	126	DQS2_B_c	174	VSS	222	CK1_B_t	270	VSS
31	VSS	79	CK0_B_c	127	DQS2_B_t	175	DQ18_A	223	CK1_B_c	271	DM2_B_n
32	DQ17_A	80	VSS	128	VSS	176	VSS	224	VSS	272	VSS
33	VSS	81	RFU	129	DQ20_B	177	DQ19_A	225	RFU	273	DQ22_B
34	DQS2_A_c	82	CA12_B	130	VSS	178	VSS	226	RFU	274	VSS
35	DQS2_A_t	83	VSS	131	DQ21_B	179	DM2_A_n	227	VSS	275	DQ23_B
36	VSS	84	CA10_B	132	VSS	180	VSS	228	CA11_B	276	VSS
37	DQ20_A	85	CA8_B	133	DQ24_B	181	DQ22_A	229	CA9_B	277	DQ26_B
38	VSS	86	VSS	134	VSS	182	VSS	230	VSS	278	VSS
39	DQ21_A	87	CA6_B	135	DQ25_B	183	DQ23_A	231	CA7_B	279	DQ27_B
40	VSS	88	CA4_B	136	VSS	184	VSS	232	CA5_B	280	VSS
Pin	Front	Pin	Front	Pin	Front	Pin	Back	Pin	Back	Pin	Back
41	DQ24_A	89	VSS	137	DM3_B_n	185	DQ26_A	233	VSS	281	DQS3_B_c
42	VSS	90	CA2_B	138	VSS	186	VSS	234	CA3_B	282	DQS3_B_t
43	DQ25_A	91	CA0_B	139	DQ28_B	187	DQ27_A	235	CA1_B	283	VSS
44	VSS	92	VSS	140	VSS	188	VSS	236	VSS	284	DQ30_B
45	DM3_A_n	93	CS0_B_n	141	DQ29_B	189	DQS3_A_c	237	CS1_B_n	285	VSS
46	VSS	94	VSS	142	VSS	190	DQS3_A_t	238	VSS	286	DQ31_B
47	DQ28_A	95	RESET_n	143	RFU	191	VSS	239	DQS4_B_c	287	VSS
48	VSS	96	VSS	144	RFU	192	DQ30_A	240	DQS4_B_t	288	RFU

7.0 DIMM Pin Description

Pin Name	Function	Pin Name	Function
CA0_A - CA12_A	Command address input to channel A.	CA0_B - CA12_B	Command address input to channel B.
CS0_A_n - CS1_A_n	DIMM Rank Select Lines input for channel A.	CS0_B_n - CS1_B_n	DIMM Rank Select Lines input for channel B.
DQ0_A - DQ31_A	DIMM memory data bus for	DQ0_B - DQ31_B	DIMM memory data bus for
CB0_A - CB3_A	DIMM ECC check bits for channel A.	CB0_B - CB3_B	DIMM ECC check bits for channel B.
CK0_A_t, CK1_A_t	SDRAM clock for channel A. (positive line of differential pair)	CK0_B_t, CK1_B_t	SDRAM clock for channel B. (positive line of differential pair)
CK0_A_c, CK1_A_c	SDRAM clock for channel A. (negative line of differential pair)	CK0_B_c, CK1_B_c	SDRAM clock for channel B. (negative line of differential pair)
DQS0_A_t - DQS4_A_t	Data Buffer data strobes in channel A. (positive line of differential pair)	DQS0_B_t - DQS4_B_t	Data Buffer data strobes in channel B. (positive line of differential pair)
DQS0_A_c - DQS4_A_c	Data Buffer data strobes in channel A. (negative line of differential pair)	DQS0_B_c - DQS4_B_c	Data Buffer data strobes in channel B. (negative line of differential pair)
DM0_A_n - DM3_A_n	SDRAM input data mask signal for write data of channel A.	DM0_B_n - DM3_B_n	SDRAM input data mask signal for write data of channel B.
VIN_BULK	5 V power input supply pin to the PMIC.	VSS	Power supply return (ground)
PWR_GOOD	Output for Power good indicator from the PMIC. The PMIC ensures this pin high when VIN_Bulk input supply, as well as all enabled output buck regulators and all LDO regulators tolerance threshold is maintained as configured in the appropriate register. Otherwise PMIC will drive this pin low. The PMIC disables its output regulator when this pin is low	PWR_EN	Power Enable. When this pin is high, the PMIC turns on the regulator. When this pin is low, the PMIC turns off the regulator.
HSCL	Side-band bus serial bus clock for SPDHub.	RESET_n	Set Register and SDRAMs to a Known State
HSDA	Side-band bus serial data line for SPDHub.	ALERT_n	Register ALERT_n output
HSA	Side-band bus Host ID and Hub device type ID selection.	RFU	Reserved for future use

8.0 Input/Output Functional Descriptions

Symbol	Type	Function
CK_t, CK_c,	Input	Clock: CK_t and CK_c are differential clock inputs. All address and control input signals are sampled on the crossing of the positive edge of CK_t and negative edge of CK_c.
CA0_A - CA6_A, CA0_B - CA6_B	Input	Command/Address Inputs: CA signals provide the command and address inputs according to the Command Truth Table. Note: Since some commands are multi cycle, the pins may not be interchangeable between devices on the same bus.
PAR_A PAR_B		
CS0_A_n - CS1_A_n, CS0_B_n - CS1_B_n	Input	Chip Select: All commands are masked when CS_n is registered HIGH. CS_n provides for external Rank selection on systems with multiple Ranks. CS_n is considered part of the command code. CS_n is also used to enter and exit the parts from power down modes.
DQ0_A - DQ31_A, DQ0_B - DQ31_B	Input	Data Input/Output: Bi-directional data bus. If CRC is enabled via Mode register then CRC code is added at the end of Data Burst.
CB0_A - CB3_A, CB0_B - CB3_B	Input	DIMM ECC check bits
DQS0_A_t - DQS4_A_t DQS0_A_c - DQS4_A_c DQS0_B_t - DQS4_B_t DQS0_B_c - DQS4_B_c	Input/ Output	Data Strobe: output with read data, input with write data. Edge-aligned with read data, centered in write data. DDR5 SDRAM supports differential data strobe only and does not support single-ended.
DM0_A_n-DM3_A_n, DM0_B_n-DM3_B_n	Input	Input Data Mask: DM_n is an input mask signal for write data. Input data is masked when DM_n is sampled LOW coincident with that input data during a Write access. DM_n is sampled on both edges of DQS. For x8 device, the function of DM_n is enabled by MR5:OP[5]=1. DM is not supported for x4 device.
LBDQ	Output	Loopback Data Output: The Output of this device on the Loopback Output Select defined in MR53:OP[4:0]. When Loopback is enabled, it is in driver mode using the default RON described in the Loopback Function section. When Loopback is disabled, the pin is either terminated or HiZ based on MR36:OP[2:0]
LBDQS	Output	Loopback Data Strobe: This is a single ended strobe with the Rising edge-aligned with Loopback data edge, falling edge aligned with data center. When Loopback is enabled, it is in driver mode using the default RON described in the Loopback Function section. When Loopback is disabled, the pin is either terminated or HiZ based on MR36:OP[2:0]

Symbol	Type	Function
ALERT_n	Input/ Output	Alert: If there is error in CRC, then Alert_n goes LOW for the period time interval and goes back HIGH. During Connectivity Test mode, this pin works as input. Using this signal or not is dependent on system. In case of not connected as Signal, ALERT_n Pin must be bounded to VDDQ on board.
RESET_n	Input	Active Low Asynchronous Reset: Reset is active when RESET_n is LOW, and inactive when RESET_n is HIGH. RESET_n must be HIGH during normal operation. RESET_n is a CMOS rail to rail signal with DC high and low at 80% and 20% of VDDQ,
HSCL	Input	Host SidebandBus bus clock, supplied by the master.
HSDA	Input/ Output	Host SidebandBus data, connected from the master to bubs or host bus client devices.
HSA	Input	Host SidebandBus bus device ID address pin; input to a hub or other client device to distinguish between identical devices in the I3C Basic address range.
RFU		Reserved for Future Use. No on DIMM electrical connection is present.
PWR_EN	Input	PMIC Enable. When this pin is high, the PMIC turns on the regulator. When this pin is low, the PMIC turns off the regulator. This pin shall not be left floating. If it is not used, it shall be tied to GND.
PWR_GOOD	Input/ Output	Power good indicator. Open Drain output. The PMIC floats this pin high when VIN_Bulk input supply as well as enabled output buck regulators and all LDO regulator tolerance threshold is maintained as configured in appropriate register. The PMIC drives this pin low when VIN_Bulk input goes below the threshold or configured in the appropriate register or and LDO output regulator exceeds the threshold tolerance. Input: The PMIC disables its output regulators when this pin is low. The LDO outputs shall remain on.
VIN_BULK	Supply	5V power input supply to the PMIC for analog circuits.
VSS	Supply	Ground

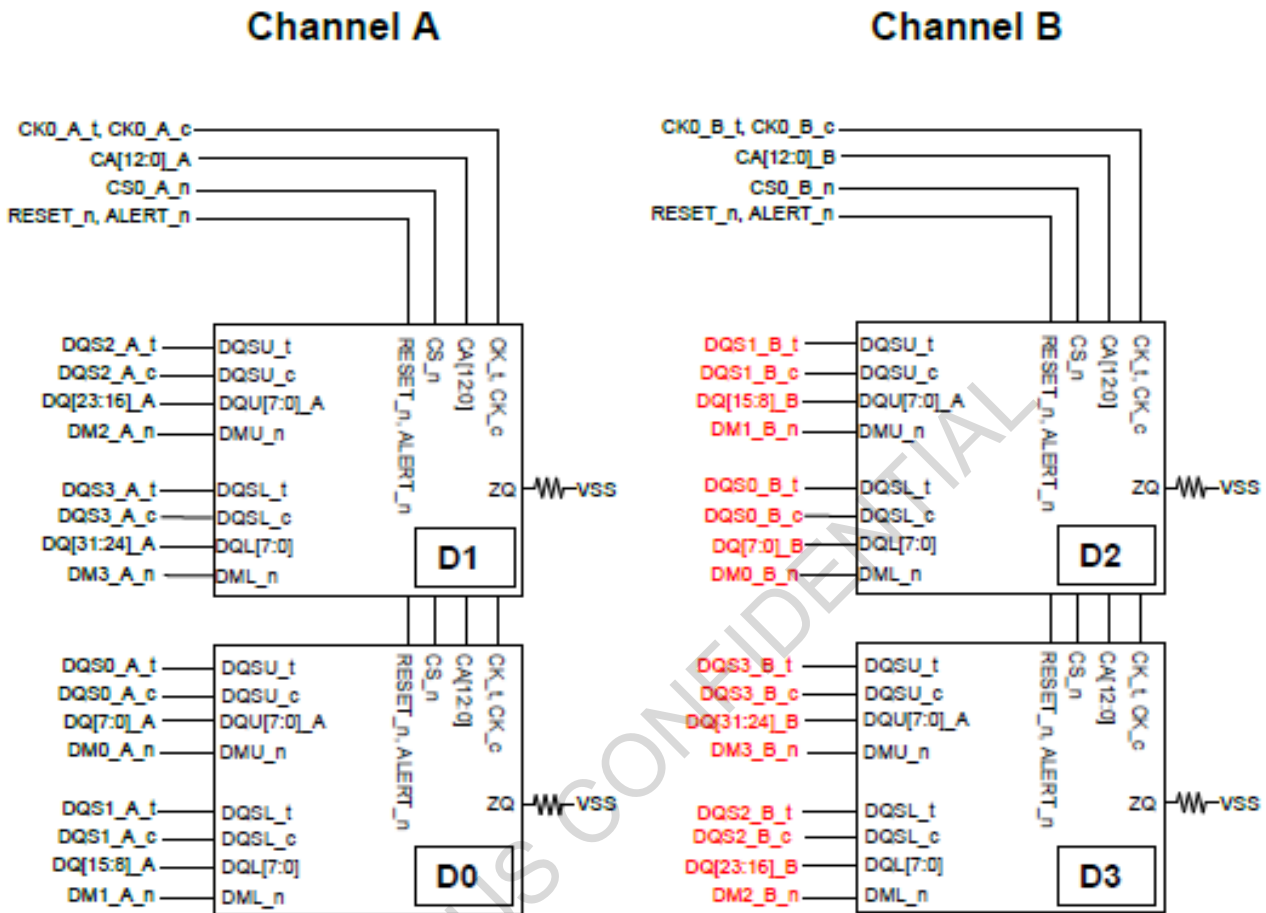
9.0 Functional Block Diagram: 8 GB, 1Gx64 Module (Populated as 1 Rank of x16)

Wirings				
Signal	Channel A		Channel B	
	D1	D0	D2	D3
CA ODT	VDDQ	VSS	VSS	VDDQ
MIR	VSS	VSS	VSS	VSS
TEN	VSS	VSS	VSS	VSS
CAI	VSS	VSS	VSS	VSS

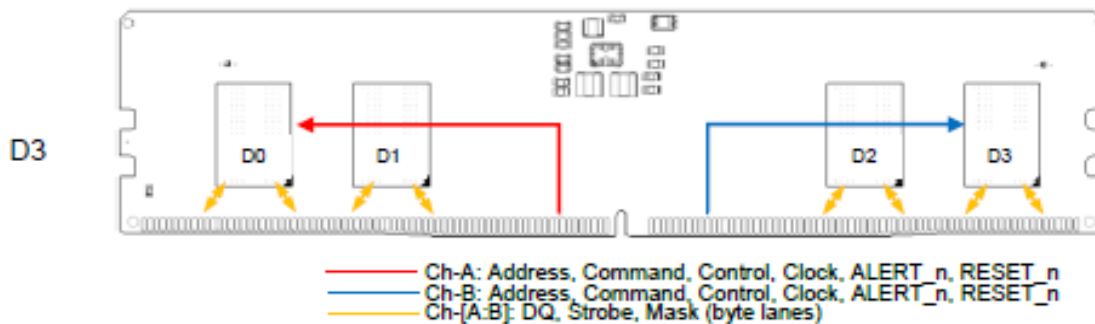

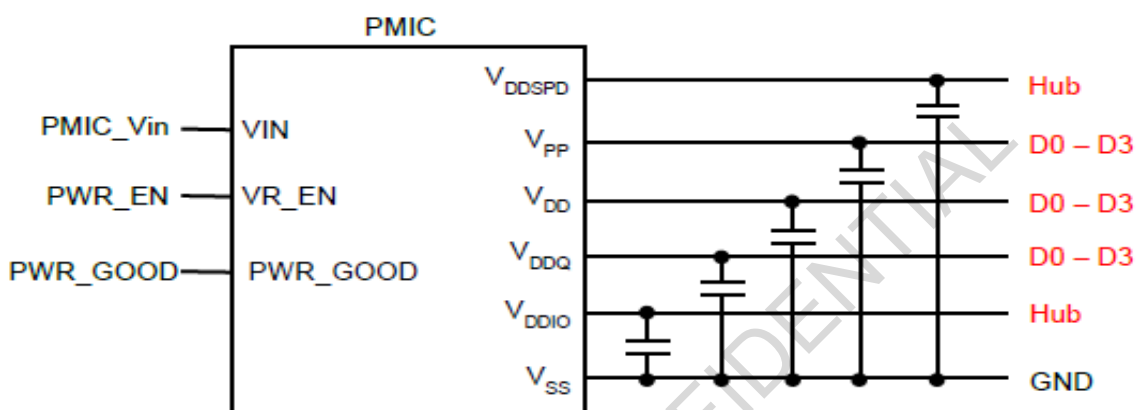
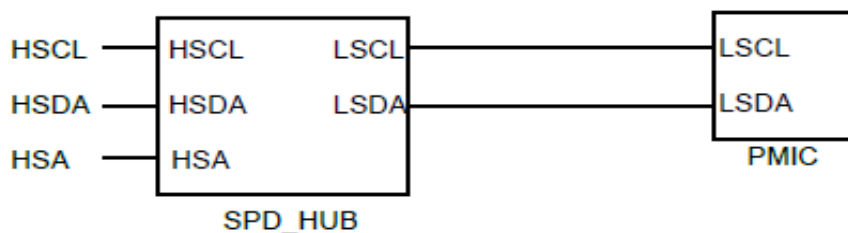

10.0 AC & DC Operating Conditions

Recommended DC operating conditions

Symbol	Parameter	Low Freq Voltage Spec Freq: DC to 2MHz				Z(f) Spec Freq: 2Mhz to 10Mhz		Z(f) Spec Freq: 20Mhz	
		Min.	Typ.	Max.	Unit	Zmax	Unit	Zmax	Unit
VDD	Device Supply Voltage	1.067 (-3%)	1.1	1.166 (+6%)	V	10	mOhm	20	mOhm
VDDQ	Supply Voltage for I/O	1.067 (-3%)	1.1	1.166 (+6%)	V	10	mOhm	20	mOhm
VPP	Core Power Voltage	1.746 (-3%)	1.8	1.908 (+6%)	V	10	mOhm	20	mOhm

11.0 IDD Specifications

I D		
Symbol	5600	Unit
IDD0	96.0	mA
IDD0F	173.2	mA
IDD2N	67.1	mA
IDD2P	55.3	mA
IDD3N	127.1	mA
IDD3P	114.7	mA
IDD4R	522.3	mA
IDD4W	671.9	mA
IDD5B	295.0	mA
IDD5F	277.1	mA
IDD5C	161.4	mA
IDD6N	59.9	mA
IDD7	665.0	mA
IDD8	27.3	mA
IDD9	209.3	mA

Module IDD is based on PMIC 5V input current, each IDD parameter includes all IDD/IDDQ/IPP of DRAM, RCD current and PMIC efficiency.

12.0 Standard Speed Bins

Speed Bin	Symbol	DDR5-5600B		Unit
CL-nRCD-nRP		46-45-45		
Parameter		min	max	
Internal read command to first data	tAA	16.000	22.222	ns
ACT to internal read or write delay time	tRCD	16.000		ns
Row Precharge Time	tRP	16.000		ns
ACT to PRE command period	tRAS	32.00	5 x tREFI1	ns
ACT to ACT or REF command period	tRC	48.000		ns
CAS Write Latency	CWL	CWL=CL-2 (38)		ns

288-Pin Unbuffered DIMM
DDR5 SDRAM

Speed Bin	tAAmin (ns)	tRCDmin tRPmin (ns)	Read CL	Supported Frequency Down Bins			
	20.952	-	22	tCK(AVG)	0.952	1.010	ns
3200C	17.500	17.500	28	tCK(AVG)	0.625	0.681	ns
3200BN 3200B	16.250	16.250	26	tCK(AVG)	0.625	0.681	ns
3200AN	15.000	15.000	24	tCK(AVG)	RESERVED		ns
3600C	17.777	17.777	32	tCK(AVG)	0.555	<0.625	ns
3600BN 3600B	16.666	16.666	30	tCK(AVG)	0.555	<0.625	ns
3600AN	14.444	14.444	26	tCK(AVG)	RESERVED		ns
4000C	18.000	17.500	36	tCK(AVG)	0.500	<0.555	ns
4000BN 4000B	16.000	16.000	32	tCK(AVG)	0.500	<0.555	ns
4000AN	14.000	14.000	28	tCK(AVG)	RESERVED		ns
4400C	18.181	17.727	40	tCK(AVG)	0.454	<0.500	ns
4400BN 4400B	16.363	16.363	36	tCK(AVG)	0.454	<0.500	ns
4400AN	14.545	14.545	32	tCK(AVG)	RESERVED		ns
4800C	17.500	17.500	42	tCK(AVG)	0.416	<0.454	ns
4800BN	16.666	16.666	40	tCK(AVG)	0.416	<0.454	ns

288-Pin Unbuffered DIMM
DDR5 SDRAM

4800B	16.666	16.250	40	tCK(AVG)	0.416	<0.454	ns
4800AN	14.166	14.166	34	tCK(AVG)	RESERVED		ns
5200C	17.692	17.692	46	tCK(AVG)	0.384	<0.416	ns
5200BN,B	16.153	16.153	42	tCK(AVG)	0.384	<0.416	ns
5200AN	14.615	14.615	38	tCK(AVG)	RESERVED		ns
5600C	17.857	17.500	50	tCK(AVG)	0.357	<0.384	ns
5600BN	16.428	16.428	46	tCK(AVG)	0.357	<0.384	ns
5600B	16.428	16.071	46	tCK(AVG)	0.357	<0.384	ns
5600AN	14.285	14.285	40	tCK(AVG)	RESERVED		ns
Supported CL					22,26,28,30,32,36,40,42,46,50		nCK

13.0 Environmental Parameters

Symbol	Parameter	Rating	Units
T _{OPR}	Operating temperature (ambient)	0 to +95	°C
H _{OPR}	Operating humidity (relative)	10 to 90	%
T _{STG}	Storage temperature	-55 to +100	°C
H _{STG}	Storage humidity (without condensation)	5 to 95	%
P _{BAR}	Barometric Pressure (operating & storage)	105 to 69	K Pascal

14.0 Physical Dimensions: (1Gx16 Based, 1Gx64, 1 Ranks)

